

This Page Is Inserted by IFW Operations  
and is not a part of the Official Record

## **BEST AVAILABLE IMAGES**

Defective images within this document are accurate representations of the original documents submitted by the applicant.

Defects in the images may include (but are not limited to):

- BLACK BORDERS
- TEXT CUT OFF AT TOP, BOTTOM OR SIDES
- FADED TEXT
- ILLEGIBLE TEXT
- SKEWED/SLANTED IMAGES
- COLORED PHOTOS
- BLACK OR VERY BLACK AND WHITE DARK PHOTOS
- GRAY SCALE DOCUMENTS
- BLANK PAGES

**IMAGES ARE BEST AVAILABLE COPY.**

**As rescanning documents *will not* correct images,  
please do not report the images to the  
Image Problem Mailbox.**

(12) **UK Patent Application** (19) **GB** (11) **2 347 445** (13) **A**

(43) Date of A Publication 06.09.2000

(21) Application No 9930398.4

(22) Date of Filing 22.12.1999

(30) Priority Data

(31) 9828234	(32) 22.12.1998	(33) GB
(31) 9900835	(32) 15.01.1999	
(31) 9923763	(32) 08.10.1999	
(31) 9924189	(32) 13.10.1999	

(51) INT CL<sup>7</sup>  
E21B 7/20 29/00

(52) UK CL (Edition R )  
E1F FCM FLA

(56) Documents Cited  
GB 2329918 A GB 2216926 A GB 1448304 A

(58) Field of Search  
UK CL (Edition R ) E1F FCM FLA  
INT CL<sup>7</sup> E21B 7/20 29/00  
Online: EPODOC, JAPIO, WPI

(71) Applicant(s)

**Petroline Wellsystems Limited**  
(Incorporated in the United Kingdom)  
Offshore Technology Park, Claymore Drive,  
Bridge of Don, ABERDEEN, AB23 8GD,  
United Kingdom

**Astec Developments Limited**  
(Incorporated in the United Kingdom)  
ODS Building, Greenbank Crescent, East Tullos,  
ABERDEEN, AB12 3BG, United Kingdom

(72) Inventor(s)  
**Paul David Metcalfe**  
**Neil Andrew Abercrombie Simpson**

(74) Agent and/or Address for Service  
**Cruikshank & Fairweather**  
19 Royal Exchange Square, GLASGOW, G1 3AE,  
United Kingdom

(54) Abstract Title

**Bore-drilling bit and bore isolation expander for single trip use.**

(57) A drill bit 22 for mounting on a drill string 10 including a section of expandable tubing 18 and a tubing expander 20. Rotation of the drill bit allows the drill string to advance through the bore 12, followed by location of the tubing 18 to overlap the existing casing 14 at 46. Tubing expander 20 is advanced through tubing 18 to expand it to a diameter close to the bore diameter. The expander engages the drill bit to allow further drilling beyond the end of tubing 18, simultaneously with the expansion of the lower end of the tubing 18. The drill bit 22 can be collapsed and retrieved with the string 10 and expander 20, leaving the expanded tubing 18 in the bore.

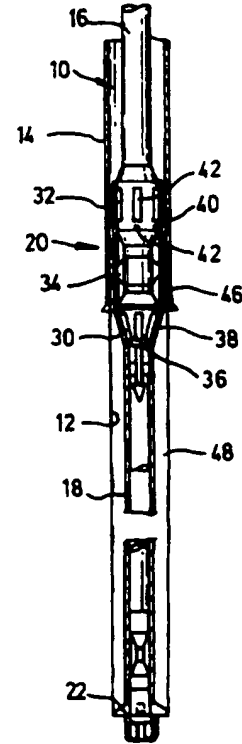

Fig. 1

At least one drawing originally filed was informal and the print reproduced here is taken from a later filed formal copy.

This print takes account of replacement documents submitted after the date of filing to enable the application to comply with the formal requirements of the Patents Rules 1995

GB 2 347 445 A

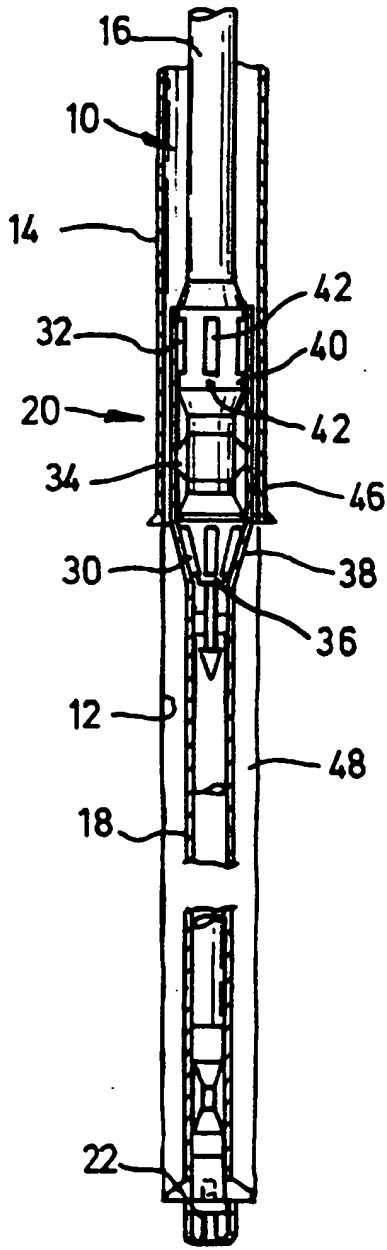

Fig. 1

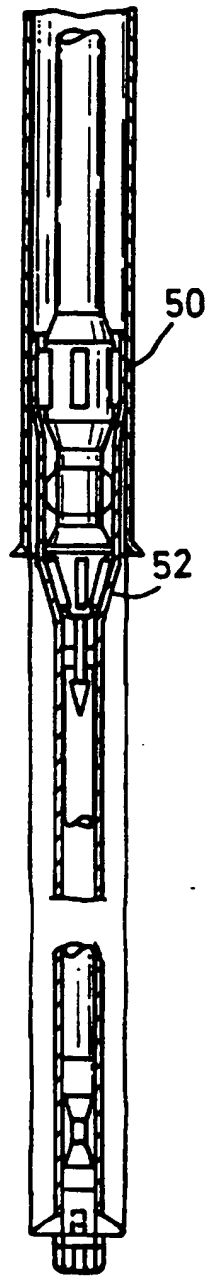

Fig. 2

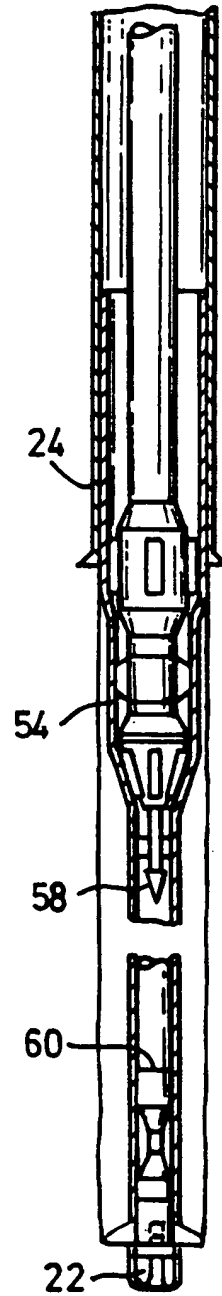

Fig. 3

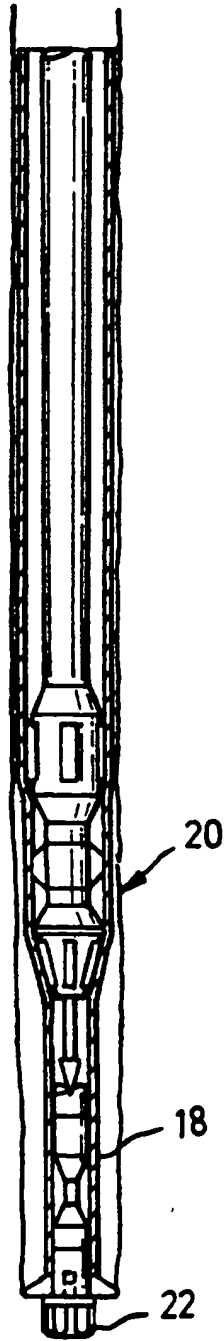

Fig. 4

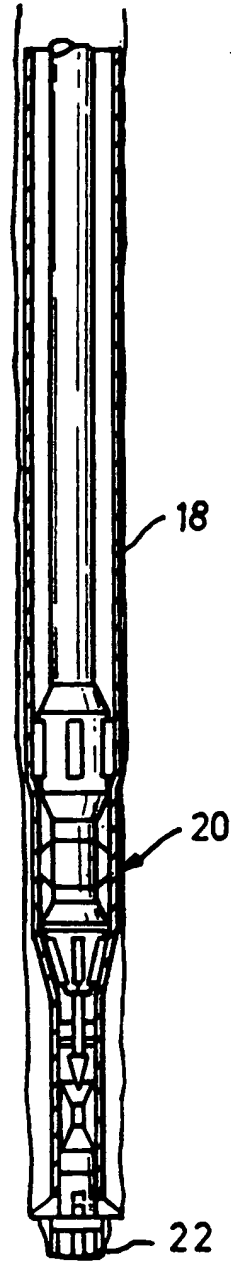

Fig. 5

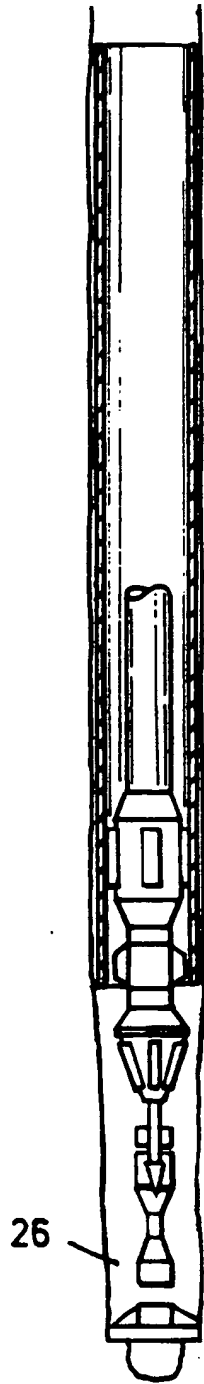

Fig. 6

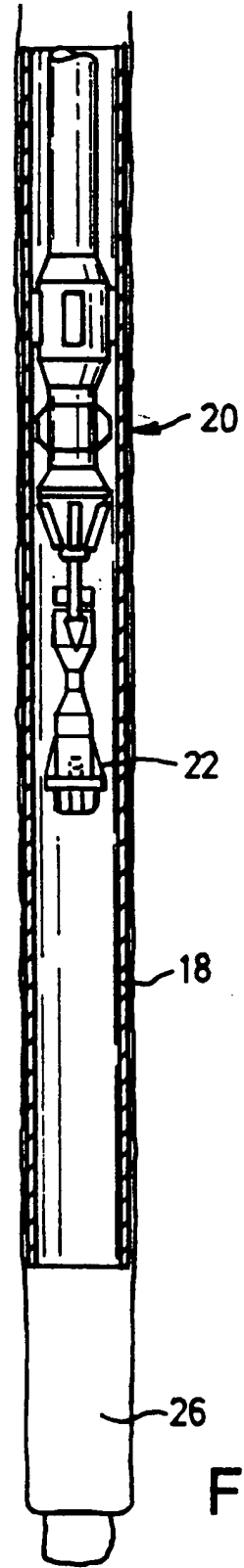

Fig. 7

DRILLING METHOD

This invention relates to a drilling method and to drilling apparatus. In particular, aspects of the invention relate to combined bore drilling and bore isolation methods and apparatus.

5 In oil and gas exploration and production operations, subsurface hydrocarbon-bearing formations are accessed by drilling bores from the surface to intersect with the formations. Drilling is accomplished using a drill bit mounted on the end of a drill support member, commonly  
10 known as a drill string. The drill string may be rotated via a top drive or rotary table on a surface platform or rig, or a downhole motor may be mounted towards the lower end of the string. The drilled bores are lined with steel tubing, known as "casing", which casing is cemented in the  
15 bore by filling the annulus between the casing and the surrounding bore wall with cement slurry. The casing *inter alia* supports the bore wall and prevents fluid flowing into or from the bore through the bore wall.

20 During a drilling operation it is normally the case that the drill string passes through an upper section of the bore, which is cased, and a lower and more recently drilled bore section which is uncased. While drilling, it is not uncommon for the bore to intersect formations which create difficulties for the drilling operator, including:

unstable formations which collapse into the bor ; swelling  
formations which restrict the bore and may trap the drill  
string in the bore; porous formations which result in loss  
of returning drilling fluid; and fluid-containing  
5 formations which result in uncontrolled flow of gas or  
liquid into the bore.

In some cases these difficulties may be overcome by,  
for example, pumping specialised fluids downhole to treat  
the problem formation. However, in other cases it may be  
10 necessary to retrieve the drill string and then run in  
casing or other bore liner to isolate the problem formation  
before drilling may recommence. Clearly, these operations  
will be time consuming and incur significant extra expense.  
Further, in the event of significant immediate problems, it  
15 may even become necessary to abandon the well.

In normal drilling operations, the sequence of events  
in drilling and then casing a bore is similar, that is  
following drilling to a desired depth the drill string is  
retrieved and a casing string is then made up and run into  
20 the bore.

It is among the objectives of embodiments of the  
present invention to provide a method and apparatus which  
permit bore drilling and bore isolation operations to be  
executed in a single "trip", that is a drill string need  
25 not be retrieved and a separate casing string run in prior  
to a bore lining or isolation operation being carried out.

According to the present invention there is provided  
a drilling method comprising:

mounting a drill bit on a drill string including a section of expandable tubing;

providing a tubing expander in the string;

advancing the drill string through a bore;

5        passing the expander through the expandable tubing to expand the tubing; and

retrieving the drill bit from the bore, through the expanded tubing.

According to another aspect of the present invention there is provided drilling apparatus comprising: a drill string including a section of expandable tubing; a drill bit mounted on the string; and a tubing expander mounted on the string, whereby the expander is operable to expand the expandable tubing downhole such that the drill bit may be retrieved through the expanded tubing.

10

15

Thus, the invention allows a section of tubing to be expanded downhole to, for example, isolate a problem formation, and the drill bit to then be retrieved through the expanded tubing. In addition, in directional drilling, other equipment such as bent subs, motors and MWD apparatus will be mounted on the string and could also be retrieved through the expanded tubing. As the expandable tubing forms part of the drill string, conveniently forming the lowermost section of the drill string, the tubing may be put in place relatively quickly, as there is no requirement to retrieve the drill string and then run in a separate string of bore liner. The invention may also be utilised to drill and line a section of bore, which may not

20

25



necessarily contain a problem formation, in a single trip. In such applications there may be occasions, for example when the bore is not to be extended further, when the drill bit may not need to be retrieved and may be left in the sump of the bore.

The expanded tubing may be cemented in the bore.

The drill bit may be a bi-centre bit or a retractable or collapsible bit, to facilitate retrieval of the bit through the expanded tubing, and also to facilitate the drilling of relatively large bores below existing casing.

When drilling below a cased section of bore it is preferred that the length of the expandable tubing section is selected to be greater than the length of the uncased section of bore, such that there is an overlap between the existing casing and the expandable tubing; the expandable tubing may be expanded at the overlap to engage the casing, and thus create a hanger for the expanded tubing. In other embodiments the expandable tubing may be otherwise located or secured in the bore.

Preferably, the expandable tubing forms the lower section of the drill string and a drill assembly, which may consist solely of the drill bit, but which may also include directional drilling apparatus, such as bent subs, motors and MWDs, is mounted to the lower end of the expandable tubing section.

Preferably, the tubing expander is initially located in an upper part of the expandable tubing, and is advanced downwards through the tubing to expand the tubing. Most

preferably, the expander and the drill bit define corresponding profiles such that, following expansion of the tubing, the expander may engage the bit and allow the bit to be retrieved with the expander. Preferably also, 5 the coupling between the expander and the drill bit is such that there may be a transfer of torque therebetween, allowing further drilling of the bore with the drill bit coupled to the expander; this may be useful to allow expansion of the lowermost part of the expandable tubing and drilling of a pocket beyond the end of the section of 10 bore lined with the expanded tubing.

Preferably, the expandable tubing is deformed by compressive plastic deformation or yield of the tubing, with a localised reduction in wall thickness resulting in 15 a subsequent increase in tubing diameter. Most preferably, the deformation is achieved by rolling expansion, that is an expander member is rotated within the tubing with a face in rolling contact with an internal face of the tubing.

Preferably, the tubing expander comprises a body and 20 one or more rolling expander members mounted on the body. The one or more expander members may be radially extendable, or may be inclined to the tubing axis to define an expansion cone. To expand the tubing, the expander is rotated and advanced through the tubing. The tubing 25 expander may comprise a plurality of expanding sections, and in the preferred embodiment two expanding sections are provided, a first section including a plurality of rollers in a conical configuration, and a second section in which

the roller axes are substantially parallel to the tubing axis. The first section may provide a degree of initial deformation by a combination of compressive and circumferential yield, while the second section may provide a subsequent degree of deformation substantially by compressive yield. Other forms of expanders may be utilised, such as a fixed cone or expansion mandrel, however the expansion mechanism of a fixed cone, that is substantially solely by circumferential yield, is such that the axial forces required to advance such a cone through expanding tubing are significantly greater than those required to advance a rolling expander through expanding tubing.

The tubing expander may be rotated from surface, or may be rotated by a downhole motor mounted to the string.

Preferably, the tubing expander is releasably axially and rotatably lockable relative to the expandable tubing, and thus may form the coupling between the expandable tubing and the remainder of the drill string. When it is desired to expand the tubing, the expander may be rotatably unlocked from the tubing. Preferably, this follows an initial deformation of a first portion of the tubing into engagement with existing casing to create an initial lock against rotation of the tubing relative to the surrounding casing. The expander is then rotated relative to the tubing to create at least a portion of a tubing hanger. The expander may then be axially unlocked to allow the expander to advance through the tubing. The lock against

relative location may be provided by couplings between the expander and the tubing which are released on initial deformation of the tubing, and the axial lock may be provided via a releasable swivel.

5           In other embodiments it may be necessary or desirable to retain a small annulus between the expandable tubing and the casing. This allows the expanded tubing to be cemented and sealed using conventional means. Further, sufficient initial torque resistance may be provided by the  
10           expandable tubing to allow the rotary expander to initiate rotary expansion before there is any contact between the tubing and the casing; for example a ball may be dropped to allow actuation of a release tool between the expander and the tubing.

15           The advancement of the tubing expander through the tubing may be achieved by application of weight, or alternatively or in addition may be achieved or assisted by provision of a suitable tractor arrangement, as described in WO93/24728, the disclosure of which is incorporated  
20           herein by reference. Such a tractor may include a plurality of rollers having skewed axes of rotation such that rotation of the tractor, with the rollers in contact with the surrounding tubing, produces an axial driving force. The rollers may be urged radially outwardly, by  
25           mechanical or preferably fluid pressure force, to grip the tubing and such that the tractor may also provide for a degree of expansion of the tubing.

The expandable tubing may take any suitable form, and

may be solid wall tubing, slotted or otherwise perforated tubing, or may incorporate sections of sand screen or the like. If the expanded tubing is to serve to isolate problem formations then clearly solid tubing will be preferred. The tubing may be provided with a seal arrangement, such as an elastomeric coating at the lower end thereof. Such an arrangement may be useful in situations where drilling fluid losses are being experienced to a formation that has been previously drilled. Losses could be mitigated by such a seal arrangement and would permit removal of the bit under safer well control conditions.

The drill string may take any appropriate form, and may be formed from drill pipe or from a reeled support, such as coiled tubing.

The expandable tubing may be expanded to a diameter close to the diameter of the drilled bore, and may be expanded such that the tubing contacts the bore wall.

According to a further aspect of the present invention there is provided a drilling method comprising:

mounting a drill bit on a drill string including a section of expandable tubing;

providing a tubing expander in the string;

advancing the drill string through a bore; and

passing the expander through the expandable tubing to expand the tubing by compressive yield.

According to a still further aspect of the present invention there is provided drilling apparatus comprising:

a drill string including a section of expandable tubing; a drill bit mounted on the string; and a tubing expander mounted on the string, the expander having at least one rolling expander member, whereby the expander is operable  
5 to expand the expandable tubing downhole by rolling expansion to produce compressive yield.

These and other aspects of the present invention will now be described, by way of example, with reference to the accompany drawings, in which:

10 Figures 1 through 7 are schematic part sectional views showing the sequence of a bore drilling and isolation method in accordance with the preferred embodiment of the present invention.

The drawings illustrate the sequence of a drilling  
15 operation in accordance with an embodiment of one aspect of the present invention, utilising apparatus of an embodiment of another aspect of the present invention. Reference is first made in particular to Figure 1 of the drawings, which illustrates the lower section of a drill string 10 being  
20 utilised to drill and extend a bore 12 below an existing section of bore which has previously been lined with casing 14. The string 10 comprises conventional drill pipe 16, which extends to the surface, and a section of expandable tubing 18 coupled to the lower end of the drill pipe section 16 via an expander 20. The expandable tubing 18  
25 extends through the uncased section of the bore 12 and provides mounting for a drill assembly including a collapsible drill bit 22. During drilling, the string 10

is rotated from surface and weight is also applied to the string 10, such that the drill bit 22 advances the bore 12. When the bore 12 has been drilled to the desired depth, the expander 20 is activated to form a tubing hanger 24 to  
5 locate the tubing relative to the casing 14 (see Figures 2 and 3). The expander 30 is then advanced through the tubing 18, and expands the tubing 18 to a diameter close to the bore diameter (Figure 4). The expander 20 then engages the drill bit 22 (Figure 5), and drilling may then  
10 recommence, beyond the end of the tubing 18, simultaneously with the expansion of the lower end of the tubing 18 (Figure 6). The drill bit 22 is then collapsed and the string 10, including the expander 20 and the drill bit 22, may be retrieved, leaving the expanded tubing 18 in the  
15 bore with a pocket 26 therebelow.

The apparatus and method will now be described in greater detail. The expander 20 comprises first and second expander sections 30, 32, with a releasable swivel 34 therebetween. The first expander section 30 features a  
20 conical body 36 which provides mounting for a number of inclined axis rollers 38, the roller axes and roller profiles being arranged such that there is minimal skidding between the rollers 38 and an adjacent conical contact surface. The second expander section 32 comprises a  
25 generally cylindrical body 40 carrying a plurality of parallel axis rollers 42. The rollers 42 are mounted on pistons and are radially extendable by application of elevated fluid pressure to the interior of the expander

section body 40. Further, the second expander section body 40 carries coupling pins 44 which, initially at least, engage the upper end of the tubing 18 and allow transfer of rotational torque from the drill pipe 16, through the expander 20, to the tubing 18.

The swivel 34 engages the tubing 18 and, initially at least, provides axial support for the tubing 18.

The length of the tubing 18 is selected to correspond to the length of the uncased section of the bore which will extend beyond the end of the casing 14 following completion of an initial drilling stage, with allowance for a suitable overlap 46 between the lower end of the casing 14 and the upper end of the expandable tubing 18. Figure 1 illustrates the point in the drilling operation when the initial drilling stage has been completed. It will be noted that the expander 20 is located in the upper end portion of the expandable tubing 18 which provides the overlap 46.

During the drilling operation, drilling mud will have been circulated through the drill string 10 to the drill bit 22, and returning through the annulus 48 between the tubing and the bore wall. On reaching the desired depth, as illustrated in Figure 1, the flow of drilling fluid is increased, leading to an increase in the internal fluid pressure within the expander 20. This activates the second expander section, such that the rollers 42 are extended radially outwardly, and deform the upper end of the tubing 18 to create contact areas 50 between the tubing 18 and the



casing 14 externally of the rollers 42. This deformation also disengages the tubing 18 from the pins 44. Thus, the expander 20 may then be rotated relative to the tubing 18, which is now fixed against rotation relative to the casing 14. The rotation of the expander 20, with the rollers 42 of the second expander section 32 radially extended, results in the deformation of the upper end of the expandable tubing 18 to create an annular section of increased diameter which forms an interference fit with the casing 14, and thus creates a tubing hanger 24. The rolling expansion of the tubing 18 results in the wall of the tubing 18 being subject to compressive yield, and the decrease of tubing wall thickness leading to a corresponding increase in tubing diameter.

The tubing 18 is now securely hung from the casing 14, and the swivel 34 may therefore be released, for example by virtue of a mechanism which is operable by a combination of application of elevated internal fluid pressure and axial force.

With the elevated fluid pressure still being applied to the expander interior, and the expander 20 being rotated, weight is applied to the string, resulting in the expander 20 advancing through the tubing 18.

The first expander section 30 is initially located in a cross-over portion of the tubing 52 where the diameter of the tubing 18 changes from a relatively small diameter to the larger diameter upper end accommodating the expander 20. During the expansion operation, the first expander

section rollers 38 move in rolling contact around the inner wall of the tubing 18, and expand the tubing to an intermediate diameter 54 by a combination of circumferential and compressive yield. The second expander section 32 produces a further expansion of the tubing 18, mainly by virtue of compressive yield.

The first stage of the expansion operation continues until a profiled member 58 extending from the expander 20 engages a corresponding female profile 60 in the upper end of the drill bit 22. On engagement of the profiles 58, 60, the drill bit 22 rotates with the expander 20, and extends the bore beyond the lower end of the tubing 18. This allows the end portion of the tubing 18 to be expanded, and also provides an uncased pocket 26 at the end of the bore 12. The string 10 may then be retrieved from the bore, together with the expander 20 and drill bit 22.

It will be apparent to those of skill in the art that the above-described embodiment offers significant time savings over conventional drilling and casing operations as it allows for drilling of a section of bore, and location of casing in a bore, in a single trip. This may be useful in conventional drilling and casing operations, and also may be useful for isolating problem formations encountered during a drilling operation.

It will also be apparent to those of skill in the art that the above-described embodiment is merely exemplary of the present invention, and that various modifications and improvements may be made thereto, without departing from

the scope of the present invention. In the above described embodiment, the expandable tubing is deformed initially to create a tubing hanger. In other embodiments a small gap or annulus may be provided between the expanded tubing and the casing, to facilitate cementing of the expanded tubing, and allowing use of other hanging and sealing arrangements. Also, in the above described embodiment a pocket is drilled beyond the end of the expandable tubing. In other embodiments, the expander may be provided with a female bit recovery device with a telescopic action, allowing complete expansion of the tubing without the need for further drilling. This may be desirable in situations where the bit has been blunted, nozzles have packed off, the bit has become stuck, or other events have occurred that make drilling difficult or impossible.

In the above embodiment expander actuation is achieved by increasing pump rates. In other embodiments, particularly where there is no requirement to drill a pocket, the expander may be actuated by dropping a ball through the string to engage a sleeve or the like to permit opening of fluid passages to allow fluid pressure actuation of the expander.

**CLAIMS**

1. A drilling method comprising:

mounting a drill bit on a drill string including a  
section of expandable tubing and providing a tubing  
5 expander in the string, then

rotating the drill bit and advancing the drill string  
through a bore, then

passing the expander through the expandable tubing to  
expand the tubing, and then

10 retrieving the drill bit from the bore, through the  
expanded tubing.

2. The method of claim 1, wherein the expandable tubing  
forms a lowermost section of the drill string.

3. The method of claim 1 or 2, further comprising the  
15 step of cementing the tubing in the bore.

4. The method of claim 1, 2 or 3, wherein the bore is  
drilled below a cased section of bore and the length of the  
expandable tubing section is selected to be greater than  
the length of the uncased section of bore, such that there  
20 is an overlap between the existing casing and the  
expandable tubing.

5. Th method of claim 4, wherein an annular gap is retained between the expanded tubing and the casing at the overlap.

5 6. The method of claim 4, wherein the expandable tubing is expanded at the overlap to engage the casing, and thus create a hanger for the expanded tubing.

7. The method of any of the preceding claims, wherein the expandable tubing forms a lower section of the drill string and a drill assembly including the drill bit is mounted to  
10 a lower end of the expandable tubing section.

8. The method of any of the preceding claims, wherein the tubing expander is initially located in an upper part of the expandable tubing, and is advanced downwards through  
15 the tubing to expand the tubing.

9. The method of claim 8, wherein the expander and a drill assembly including the drill bit define corresponding profiles and, following at least partial expansion of the tubing, the expander engages the assembly and the assembly  
20 is retrieved with the expander.

10. The method of claim 9, wherein the profiles for engaging the expander and the drill assembly permit transfer of torque therebetween, and further drilling of the bore is carried out with the drill bit coupled to the

expander.

11. The method of any of the preceding claims, wherein the expandable tubing is deformed by compressive plastic deformation of the tubing, with a localised reduction in wall thickness resulting in a subsequent increase in tubing diameter.

12. The method of claim 11, wherein the deformation is achieved by rolling expansion, that is an expander member is rotated within the tubing with a face in rolling contact with an internal face of the tubing.

13. The method of any of the preceding claims, wherein a first section of the expander provides a degree of initial deformation by a combination of compressive and circumferential yield, and a second section of the expander provides a subsequent degree of deformation predominantly by compressive yield.

14. The method of claim 6, wherein the tubing expander is releasably axially and rotatably lockable relative to the expandable tubing, and provides a coupling between the expandable tubing and the remainder of the drill string and when the tubing is to be expanded the expander is rotatably unlocked from the tubing following an initial deformation of a first portion of the tubing into engagement with existing casing to create an initial lock against rotation

of the tubing relative to the surrounding casing, the expander is then rotated relative to the tubing to create at least a portion of a tubing hanger, and the expander is then axially unlocked and the expander advanced through the  
5 tubing.

15. The method of any of the preceding claims, wherein the string is reelable.

16. Drilling apparatus comprising: a drill string including a section of expandable tubing; a drill bit  
10 mounted on the string; and a tubing expander mounted on the string, whereby the expander is operable to expand the expandable tubing downhole such that the drill bit may be retrieved through the expanded tubing.

17. The apparatus of claim 16, wherein the expandable  
15 tubing forms a lower section of the drill string.

18. The apparatus of any of claims 14 to 17, wherein the drill bit is a collapsible bit.

19. The apparatus of any of claims 14 to 17, wherein the drill bit is a bi-centred bit.

20. The apparatus of any of claims 14 to 18, wherein the  
20 expandable tubing forms a lower section of the drill string and a drill assembly including the drill bit is mounted to

the low r end of the expandable tubing section.

21. The apparatus of any of claims 14 to 20, wherein the tubing expander is initially located in an upper part of the expandable tubing.

5 22. The apparatus of any of claims 14 to 21, wherein the expander and a drill assembly including the drill bit define corresponding profiles such that the expander may engage the bit and allow the bit to be retrieved with the expander.

10 23. The apparatus of claim 22, wherein the engagement between said profiles is such that there may be a transfer of torque therebetween.

15 24. The apparatus of any of claims 14 to 24, wherein a lower portion of the expandable tubing carries an external seal arrangement for cooperating with a surrounding bore wall.

25. The apparatus of any of claim 14 to 24, wherein the tubing expander comprises a body and at least one rolling expander member mounted on the body.

20 26. The apparatus of claim 24, wherein the at least one expander member is radially extendable.



27. The apparatus of claim 24 or 25, wherein the at least one expander member is inclined to the tubing axis to define an expansion cone.

5 28. The apparatus of claim 24, 25 or 26, wherein the tubing expander comprises at least two roller expanding sections, a first section including a plurality of rollers in a conical configuration, and a second section including a plurality of rollers having roller axes which are substantially parallel to the tubing axis.

10 29. The apparatus of any of claims 14 to 28, wherein the tubing expander is at least one of releasably axially and rotatably locked relative to the expandable tubing, and forms a coupling between the expandable tubing and the remainder of the drill string.

15 30. The apparatus of claim 29, wherein the rotation lock is in the form of couplings between the expander and the tubing which are releaseable on initial deformation of the tubing.

20 31. The apparatus of claim 29 or 30, wherein the axial lock is a releasable swivel.

32. Drilling apparatus comprising: a section of expandable tubing for mounting to a lower end of a drill string; a drill bit mounted on a lower end of the expandable tubing;

and a tubing expander, whereby the expander is operable to expand the expandable tubing downhole such that the drill bit may be retrieved through the expanded tubing.

33. A drilling method comprising:

5 mounting a drill bit on a drill string including a section of expandable tubing;

providing a tubing expander in the string;

advancing the drill string through a bore;

locating the expandable tubing in the bore; and

10 passing the expander through the expandable tubing to expand the tubing by compressive yield.

34. Drilling apparatus comprising: a drill string including a section of expandable tubing; a drill bit mounted on the string; and a tubing expander mounted on the string, the expander having at least one rolling expander member, whereby the expander is operable to expand the expandable tubing downhole by rolling expansion to produce compressive yield.

35. Drilling apparatus comprising: a section of expandable tubing for mounting to a drill string; a drill bit for mounting on the tubing; and a tubing expander, the expander having at least one rolling expander member, whereby the expander is operable to expand the expandable tubing downhole by rolling expansion to produce compressive yield.